

## Fireriser® Butterfly Valve

Grooved Normally Closed Type 300PSI

Fig No.:FPB-300G

### Valve Standard:

Conforms To MISS SP67 | BS EN 593:2009

### Working pressure:

300 PSI (21 Bars)-Non Shock Coldwater  
Max.Test Pressure: 600 PSI (42.8 Bars)/FM Standard 1112

### Temperature:

from -20 ° C to 110° C

Factory installed UL, listed double Tamper Switches  
Valve Approved For Indoor and Outdoor Use  
Fusion Bonded Epoxy Coated Interior and Exterior RAL3000

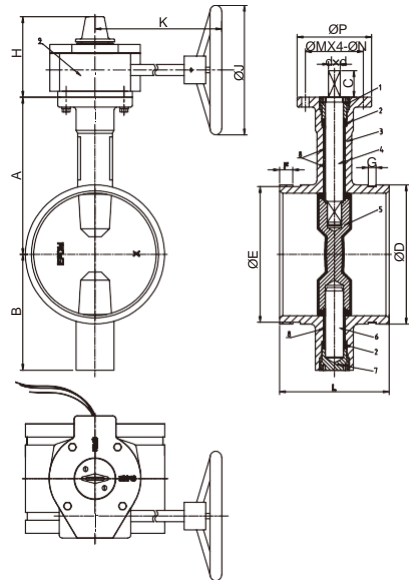

**Grooved Ends** to suit BS or ANSI pipe size

### Materials List

Name	Material
Signal Gearbox	Ductile Iron ASTM A536 65-45-12
Lower Shaft Sealing Nut	WCB ASTM A216
Lower Shaft	Stainless Steel SS416
Disc	DI+EPDM
Upper Shaft	Stainless Steel SS416
Body	Ductile Iron ASTM A536 65-45-12
Shaft Seal	EPDM
Upper Shaft Sealing Nut	WCB ASTM A216

### Dimensions(inch):

Size	A	B	C	D	E	F	G	H	K	J	P	M	N	d	L
2.5"	120	95	32	73/76.1	72.1	15.9	7.9	111	218	152	90	70	9	10	96.4
3"	140	100	32	88.9	84.9	15.9	7.9	111	218	152	90	70	9	11	97
4"	160	100	32	114.3	110.1	15.9	9.5	111	218	152	90	70	9	14	115.1
5"	170	125	32	139.7/141.3	137	15.9	9.5	111	218	152	90	70	9	14	132.4
6"	190	140	32	165.1/168.3	164	15.9	9.5	111	218	200	90	70	9	16	132.4
8"	230	175	32	219.1	214.6	19	11.1	126	232	290	125	102	12	19	147.4
10"	260	200	45	273	268.3	19	12.7	126	232	290	125	102	12	22	159
12"	300	240	45	324	318.3	19	12.7	161	252	350	150	125	14	24	165

### Net Weight (kg) and Crate Qty (pcs)

Size	2.5"/65	3"/80	4"/100	5"/125	6"/150	8"/200	10"/250	12"/300
Net Weight	8.40	9.10	10.10	13.80	14.70	28.70	37.40	72.70
Crate QTY	30	25	25	18	16	8	5	3

### Notes:

UL Listed All Sizes 2-1/2" to 8" FM Approved and 10" to 12" Pending

Fivalco® and Fireriser® are Registered Trade Marks

Copyright Fivalco 2000