

FEATURES & SPECIFICATIONS

- Valve conforms to MSS SP-67 / BS EN593: 2009
- Design and test standard conforms to FM1112 and UL1091
- Fusion bonded epoxy coated RAL3002
- Fitted with visual indicator and supervisory switch
- EPDM encapsulated disc
- Valve suitable for indoor and outdoor installation
- Grooved ends to suit AWWA or BS pipe size
- Working pressure : 300psi - Non Shock Coldwater
Max. Test Pressure : 600psi
- Working temperature : -10°C ... 120°C



MATERIALS LIST

Name	Material
Body	Ductile Iron ASTM A536 65-45-12
Disc	Ductile Iron ASTM A536 65-45-12 + EPDM
Lower Shaft	Stainless Steel SS410
Upper Shaft	Stainless Steel SS410
Signal Gearbox	Ductile Iron ASTM A536 65-45-12
O-Ring	EPDM
Bushing	Bronze ASTM B150M C63000
Gland	Galvanized Carbon Steel Surface Passivation
Washer	Galvanized Carbon Steel Surface Passivation
Plug	Galvanized Carbon Steel Surface Passivation
Gear Box Fasteners	Galvanized Carbon Steel Surface Passivation

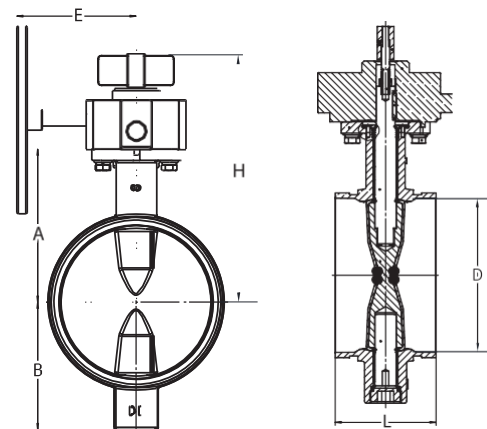

DIMENSIONS (Inch)

Size	2"/50	2.5"/65	3"/80	4"/100	5"/125	6"/150	8"/200	10"/250	12"/300
A	3.74	3.86	4.13	5.31	5.83	6.49	8.03	9.65	10.93
B	2.83	3.07	3.35	4.13	5.04	5.51	6.69	8.07	10.17
L	3.33	3.86	3.86	4.57	5.87	5.81	5.28	6.29	6.49
E	4.92	4.92	4.92	4.92	5.51	5.51	6.26	6.26	8.98
H	8.39	8.50	8.78	9.96	10.59	11.22	12.79	14.69	15.89
D	2.37	2.87 / 2.99	3.5	4.5	5.5 / 5.56	6.5 / 6.63	8.63	10.75	12.75

NET WEIGHT (kg) & CRATE QTY (pcs)

Size	2"/50	2.5"/65	3"/80	4"/100	5"/125	6"/150	8"/200	10"/250	12"/300
N.W.	4.4	4.9	5.2	6.3	11.7	14	22.1	36.2	50.2
Crate Qty	90	80	70	60	50	40	20	10	10